

Catena di trasporto rinforzata

Catena rinforzata per alimentatori a vassoi abbattibili e per elevatori a tazze, con alette di attacco e appoggi per le tazze.

Reinforced conveyor chain

Reinforced chains for folding tray feeders and bucket elevators with attachments and bucket supports.

Cadena de transporte reforzada

Cadenas reforzadas para alimentadores de bandejas abatibles y para elevadores de cangilones con aletas de sujeción y apoyo para los cangilones.

DIN 8175



Vassoi abbattibili
Folding trays
Bandejas abatibles

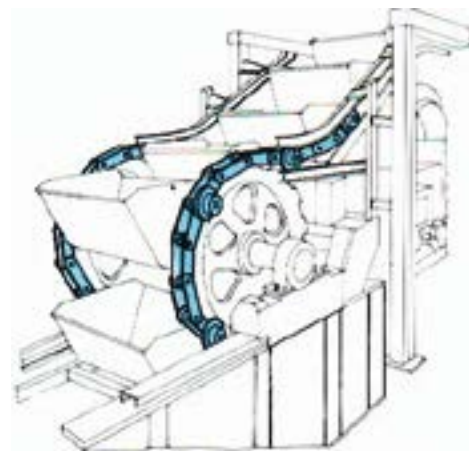

Elevatori a tazze
Bucket elevators
Elevadores de cangilones

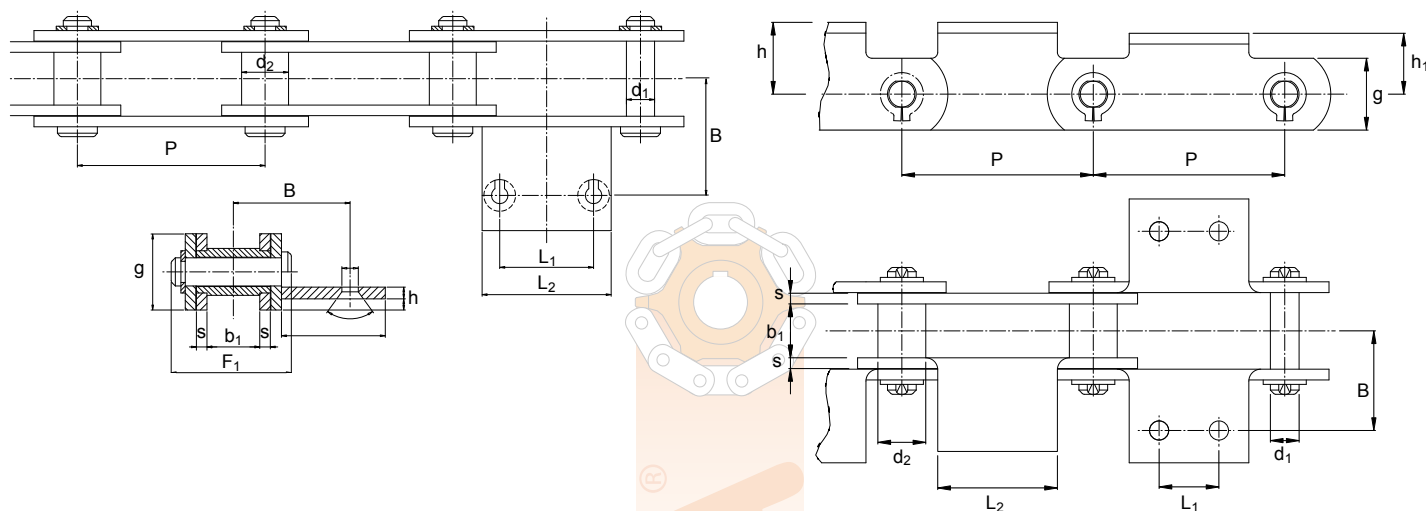

Fabbricata con acciai e materiali CICSA ad alta resistenza.
Manufactured with CICSA high resistance steels and materials.
Fabricadas con aceros y materiales CICSA de alta resistencia

Codice Code Código	Dimensioni / Dimensions / Dimensiones mm											Massa Mass Masa kg	MBF kN
	Passo Pitch Paso	Ø Bussola Bush Casquillo	Altezza aletta Attach. height Altura aleta	Ø Perno Pin Eje	Centro catena Chain center Centro cadena	Massa	MBF						
	P	d ₂	h ₁	d ₁	B	F ₁	kg	kN					
CX-30	160	32	36	20	62	78	11.8	220					
CX-45	160	40	40	26	74	105	18.2	450					
CX-60	160	44	70	30	80	130	34.4	600					
CX-70	160	54	100	36	85	135	37.6	700					
CX-75	160	54	100	36	90	135	45.2	800					